EFFECT OF PERFORMANCE MANAGEMENT SYSTEMS ON EMPLOYEE PERFORMANCE IN STATE CORPORATIONS IN KENYA: A STUDY OF KENYA MEAT COMMISSION

Okero Isaac Onsarigo, School of Business and Economics, Kisii University, Kenya
Dr. Stella Moraa Omari, PhD, School of Business and Economics, Kisii University, Kenya
Dr. Wanyama Kadian Wanyonyi, PhD, School of Business and Economics, Kisii University, Kenya

Accepted: January 27, 2021

ABSTRACT

The purpose of this research was to establish the influence of performance management systems on employee performance of Kenya Meat Commission, Kenya. The study was guided by the following objectives, to determine the effect of performance planning system on employee performance at the Kenya Meat Commission and to evaluate the effect of performance appraisal system on employee performance at the Kenya Meat Commission. The researcher used a descriptive research design and the population under consideration included 200 staff at the KMC and a sample size of 144 respondents. Structured questionnaires were used to collect the data. The information gathered from the study was analyzed by percentages, frequency distributions, and the findings were presented by the use of tables and charts. It was concluded that there was a statistically significant positive relationship between performance planning system, performance appraisal system and employee performance of Kenya Meat Commission. Performance planning system explained 28.4% variations in the employee performance of Kenya Meat Commission, performance appraisal system accounted for 24.4% of variance in the employee performance of Kenya Meat Commission. The recommendations of the study were that the management should invest more in the performance management systems (performance planning system, and performance appraisal system) which has been established to have had a positive effect on the employee performance. The Kenya Meat Commission should strengthen their performance appraisal and ensure that they are operational since they have been proved to improve employee performance. This study would help KMC to execute the most fitting, advantageous and viable performance management system.

Keywords: *Performance Planning, Performance Appraisal*

INTRODUCTION

Performance Management System is an instrument that is used to evaluate the efficiency of the entity's overall performance. As such it is important that performance dimensions' focus on the core mandate that supports quality service delivery within a public institution. It obligates members of staff to enhance productivity by ensuring that they set smart targets and clear strategic actions towards the attainment of the organization's objectives (Ochieng, 2015).

Assish (2018) considered performance planning, performance appraisal, and reward system forms of performance management systems as the foundation for determining the income potential of every employee in an organization. Such systems were used to determine if the earnings of every employee are justified based on individual input towards the attainment of organizational goals.

Employee Performance Appraisal is considered as a process that involves individual employees, the management, organizational goals, and past performance. The administration will use the gathered data to assess the possibility of utilizing the available human power to project future employee competencies and emoluments and understand whether the firm will ultimately attain its strategic objectives. Even if performance appraisal is important and necessary in an organization, it should not be considered as a replacement for performance management. Rather, it should be considered as one of the primary parameters for determining or managing employee performance index (Kariuki, 2014).

Established by an Act of parliament 363 in 1950 Kenya Meat Commission is mandated to consistently guarantee sustainable livelihoods especially for people in the ASAL areas as an intervention to the vagaries of weather that have become cyclic, necessitating livestock off take among vulnerable communities. It focuses its resources towards contributing to food security and sustainable incomes by processing meat, offer high quality products and services thus leveraging Agenda 4 and Vision 2030 through value addition of meat and meat products, processes quality hides and skins in support of The Big Four Agenda of manufacturing and agro processing, procure quality livestock for processing into canned corned beef to be released during times of drought and famine to mitigate hunger, achieve food security, improved nutrition and promote sustainable agriculture (Strategicplan, 2015).

The factory was re-opened in 1989 only to close again in 1992 following its inability to sustain operations due to losses occasioned by KMC's buyer of last resort status and obsolescence of the factory's machinery and equipment. Following the 1992 closure, the Government of Kenya with the financial and technical support of Mitsubishi Corporation (UK) Limited set out to rehabilitate the Athi-River factory, a task that was completed in 1995, after a successful test run. However, the factory remained closed until 2006.

As per KMC staff data (2019), the Commission's workforce sum to 317 whereby 70% is direct and unskilled labor while 30% is indirect labor. However, this number has been diminishing definitely based on a high rate of staff turnover being experienced. A number of staff post-employment survey records have demonstrated that most of the exceptionally productive and educated workers leave the commission looking for better working conditions and performance frameworks.

To address the challenges of bloated and unskilled workforce, KMC has, therefore, to operationalize staff Rationalization Strategy- due to the ongoing modernization of KMC machinery, a lean workforce, therefore, will be required to run the production processes efficiently. The rationalization strategy is voluntary early retirement and if the projected number is not achieved forced separation can be the next available option. Voluntary separation is a negotiated option and has the least risk of legal challenge and if it is forced separation the criteria to be used should be objective to avoid charges of discrimination. This will pray a key role in ensuring that KMC

develops and maintains a pool of skilled workforce that will result in high employee Performance and organizational development.

Statement of the Problem

Many organizations including public corporations are today faced with a competitive business environment due to the operationalization of the open market policy and advancement in communication technology. The performance management system is aimed at driving forward improvement in public service delivery and enhancing the sustainability of employee Performance. PM activities like performance appraisal, communication and feedback, reward systems and performance contracting have been focused upon as affecting employee Performance in different state corporations.

However, these performance management practices seem not to have been looked at in their entirety as factors affecting employee Performance among public corporations like Kenya Meat Commission. For instance, one of the core activities that ensures achievement of the core mandate of the organization and improved employee Performance goal is the number of the meat and meat products produced in support of the Big Four Initiatives and Vision 2030 Flagship Projects. For instance, during the last financial year of 2019/2020 KMC procured 2,926 large stock and 826 shots against the target of 17,498 livestock. A drop of 352 metric tonnes of meat and meat products against the target of 700 metric tonnes was recorded as well. These were indicators of ineffectiveness of human resource management practices including performance management in the organization. Scholars have linked performance management system practices with improved employee Performance. However, scanty information seemed to be available with regard to the application of the aforementioned performance management practices with an aim to enhancing employee Performance in KMC.

Objectives of the study

The general goal of this research was to determine the effect of performance management systems on employee performance in Kenya's State Corporations.

The following specific objectives guided the research:

- To determine the effect of performance planning system on employee performance at the Kenya Meat Commission.
- To evaluate the effect of performance appraisal system on employee Performance at the Kenya Meat Commission.

The following research hypotheses guided the research:

- H₀1: Performance planning system has no significant effect on employee Performance at the Kenya Meat Commission
- H₀2: Performance appraisal system has no significant effect on employee Performance at the Kenya Meat Commission

LITERATURE REVIEW

Goal-Setting Theory

In 1968, Edwin Locke proposed the theory and is based on the assertion that individual objectives assume a specific pattern job in inspiring them to attain higher positions. However, if the level of performance improves, it will enable the accomplishment of the set goals under the performance management system (Serra, 2017). The theory alludes to the impacts of defining objectives on resulting performance or goals. Edwin Locke asserted that people who set explicit, complex goals performed relatively better than the individuals who set general, simple objectives (Serra, 2017). The goal-setting hypothesis expresses that specific objectives with timely feedback add

to improved performance. Such objectives enable the worker to perform tasks effectively. It further encourages the workers in understanding the level of effort required to attain optimal performance (Bhattacharya, 2016).

As indicated by Edwin's theory, there are two psychological determinants of human behavior: values and goals. An objective is essentially considered as what an individual is intentionally attempting to do. Edwin and Latham assert that the structure in which an individual will encounter other's worth decisions is enthusiastic, meaning that values will create the desire to do things steady with them. Objectives additionally influence conduct (work execution) through different systems. For Edwin and Latham, objectives, in this manner, control attention and activity. Based on the theory, the necessary feedback of results enables the worker to perform better rather than lack of change in case of mistakes. Giving feedback should be considered as a strategy to gain an appropriate reputation and avoidance of some troubles. It encourages workers to work with greater inclusion and prompts job satisfaction (Bomett, 2015).

Justice Theory

Employee evaluation is an extremely emotional procedure. Aswani, (2018) contends that the precise and objectivity of a worker's performance are ordinarily inaccessible. Rather, performance is checked from abstract sentiments given by bosses and this type of subjectivity opens an avenue for bias where the managers utilize their capacity to reward favored subordinates past their actual level of output. The adverse effects of such forms of evaluation have two ramifications for the plan of remunerations. The use of incentives will be de-underlined and preference makes organizations to utilize bureaucratic principles in compensation and job promotion decisions.

Albeit frequently talked about, the expressions "rewards" and "acknowledgment" do allude to various ideas. As a rule, the term rewards are closely associated with compensation measures which are characterized as the purposeful procedure of the payment programs as a fundamental incorporating component that enables the endeavors of different sub-units or people to be coordinated towards the accomplishment of vital goals (Al-Alawi, 2018). They include the management tools which ideally add to the organization's capability by impacting overall behavior (Hearn, 2017). Organizations use to payment systems and promotions or different sorts of remunerations to realize high-performance standards (Jugmohun, 2018).

Kamencu (2011) applied the exchange theory to consolidate every one of the four equity measurements into one hypothetical system. The findings revealed that procedural, interactional, relational, and educational equity are closely linked with social connections, either with the place of work (for example procedural equity) or with the manager (for example interactional, relational, and informational equity), though distributive equity is connected more to a financial trade relationship. In the present research, it is necessary to draw upon this integrative structure and apply it explicitly to a performance appraisal setting. This conceptualization may hold the way to clarifying representatives' impression of reasonableness concerning their performance appraisals and employee evaluation frameworks. Underneath, it is necessary to examine important previous performance appraisals research relating to every one of the four equity measurements.

Empirical Review

The performance agreements put in perspective expectations while at the same time creates a common point of reference for senior management, staff, and supervisors in the entire PMS process. The performance agreements clearly state the standards of performance which a government requires public officials, or the management of state-owned or public agencies or ministries to meet over some time (Pulakos, 2004) cited by (Aguinis, 2019).

Employee performance management is an exercise where all employees have a shared values concerning the goals of the organization and how to achieve the objectives as captured by Weiss *et al.* (1997) cited by Korir *et. al* (2015). Organizational objectives are well aligned with the employees agreed targets, skills, and the delivery of

results. The emphasis is on continual improvement, learning, and development to create a high-performance workforce while achieving the overall organization strategy. When a performance management system is implemented accurately, linking specific objectives to the strategic and operational plans, institutional performance outcomes will more likely increase very steadily.

According to the study Muthina (2017) conducted in Kenya on Performance Of Commercial State Corporations. The study highlighted that performance planning system is the first most important component of the performance management process since it's the basis of performance appraisals. It is during this time that employees decide collectively on the targets and identify the key performance areas which can be attained over one year. This is usually within the performance budget and is finalized after a mutual agreement between the reporting officer and the employee.

Buuri (2015) did a study on Performance measurement practices and employee productivity in the insurance firms in Kenya. Results indicate that most insurance firms used the Balanced Scorecard performance measurement model and the strength of the relationship between employee productivity and each of the performance measurement practices reported was moderate. Current study, though with some limitations in term of response and scope of study has served the purpose of initiating researching on performance measurement in the insurance industry, which can be used as a basis for further study and benefit to the management of organizations in the service industry. The study recommended further research can be carried out to firms in other service sectors to establish the performance measurement practices used and if they influence the productivity of the employees. This would enable managers to focus on the issues that positively influence both individual and Employee performance.

A research by Saleem (2015) demonstrates that the connection between self-examination and evaluation of others had three results the respondents shown a "self-different bias". Positive characteristics were more unmistakable of self than others. For those with high confidence, they had a comparative respect for other people. They likewise assessed themselves as positively than other individuals. Self-assessments were more ideal than assessments of companions. Individuals with high confidence evaluated their colleagues more decidedly than they assessed the normal individual. It was additionally discovered that the inclination for those with high confidence to positively pass judgment on themselves and their colleagues demonstrating an extreme requirement for social endorsement. The discoveries shed light on inspiration to upgrade self-esteem and are incorporated with current proof that the utilization of self-improving systems advances mental prosperity.

In Nigeria, an Empirical study conducted by Abdulkadir *et al.*, (2012) on effects of strategic performance appraisal, career planning and employee participation on organizational commitment. This study adopted a descriptive survey among fourteen Nigerian banks. The study employed G-test, regression analysis and correlation analysis in testing the hypotheses. The study findings revealed that performance appraisal system, career planning systems and employee participation had a significant influence on employee job commitment and the level of organization commitment of employees in the Nigerian Banking industry is quite low. The study recommended that workers needs to be committed to their works. Employees should make conscious efforts towards strategically managing performance appraisal, career planning and employee participation with an objective of ensuring the desired results remain realistic and attainable.

An investigation done by Kariuki (2014) indicates that performance appraisal is considered to be an occasional assessment of an employee's work by measuring it against the activity's expressed or assumed prerequisites. He states that performance appraisal has been connected to representative inspiration and adequacy in terms of service delivery. Moreover, it assumes a significant job in employees' level of satisfaction and this creates

inspiration, and commitment towards the employer. Research gap exists in countries like Kenya, on the significance of performance evaluation and its real impact on an organization so to reveal that hole we are finding the effect of performance appraisal on workers' duty in the government sector.

A research directed by Munguti (2017) presumed that the execution of the performance management system encourages development and wellbeing of workers. It is basic that the administrators actualizing the concept have a positive feeling towards it and comprehend its advantages. Nonstop observation and training of employees and managers is significant with the goal that a high quality of service is offered.

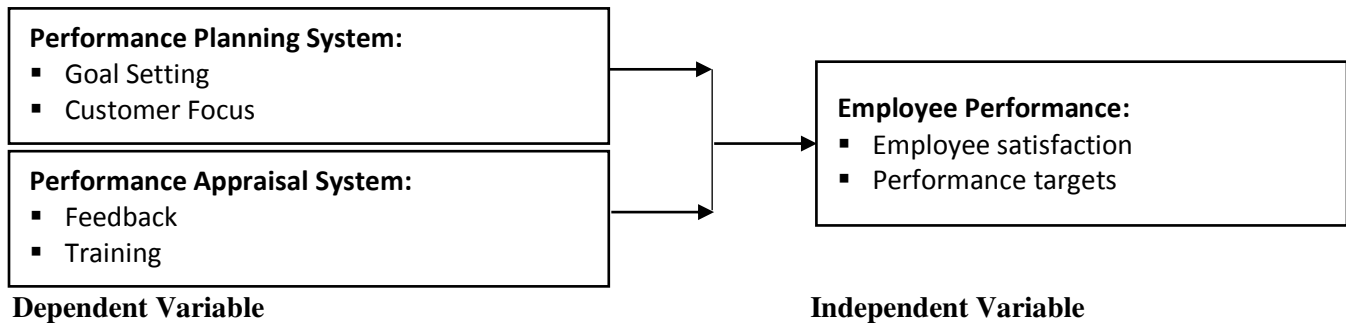

METHODOLOGY

This study adopted a descriptive research design. Stratified sampling was done from 13 departments with the aim of covering 144 employees. Wanga, (2018) demonstrates that targeting about 50% - 60% is a sufficient number in descriptive research study. Primary data was, therefore was gathered using organized or structured questionnaires.

RESULTS AND DISCUSSION

A total of 144 questionnaires were issued to the respondents and 130 questionnaires were filled and returned. This represented a return rate of 90.3% which was good when compared to the recommended response rate to verify consistency of measurements required for analysis (75% based on Nachimias and Nachimias, 2005). Missing data of fourteen (14) questionnaires were handled in the following ways: encoded missing data as 9999; replacing missing values with the mean/median value of the feature in which they occur; labelling encoded 9999 as another level of a categorical variable; running predictive models that impute the missing data and using the number of missing values in a given row to create a new engineered feature. Table 1 showed this information;

Table 1: Questionnaire Return Rate

Questionnaire	Number	Percentage %
Delivered	144	100
Returned	130	90.3
Not returned	14	9.7

Source: Research Data (2020)

Control of Type I and II errors

The control Type I and Type II errors is critical in the validity of the statistical findings in that wrong interpretation of results may occur during tests of various statistics. Type I error occurs when the null hypothesis is rejected when it was supposed to be accepted while Type II error occurs when the null hypothesis is accepted when it was supposed to be rejected (Larry, 2013). The study controls both Type I and II errors from occurring by specifying $p \leq 0.05$ levels and thus the researcher was able to establish the level of acceptable statistical significance.

Performance Management Systems and Employee Performance

Descriptive and inferential statistics results on the performance management systems and Employee performance of Kenya Meat Commission were based on a five Likert scale where; 5=Strongly Agree, 4=Agree, 3=Undecided, 2= Disagree, 1= Strongly Disagree. The mean and standard deviation were computed from the respondents' responses using these descriptive statistics.

Performance planning and Employee Performance

The objective on the performance planning system had seven (7) questions; their means, standard deviations, Skewness (extent to which a given distribution varies from a normal distribution) and Kurtosis (measure of outliers present in the distribution) results were as shown in the Table 2. The question on whether employees are involved in goal setting during performance management system process had a mean of 2.9154 with standard deviation of 1.40340, with skewness of 0.016 and kurtosis of -1.400. The question on whether there was constant supervision by the immediate supervisor is a good technique to encourage employees to perform well had a mean of 3.4077 with standard deviation of 1.22440, with skewness of -0.671 and kurtosis of -0.609; on whether there was a link between the current performance and employee goals in the organization had a mean of 3.1016 with standard deviation of 0.97883, with skewness of -0.565 and kurtosis of -0.821; on whether there were performance targets for the employees set by their supervisor had a mean of 3.2422 with standard deviation of 1.22793, with skewness of -0.423 and kurtosis of -0.944; Table 2 showed a relationship between descriptive statistics of performance planning system and employee performance.

Table 2: Descriptive Statistics of Performance Planning System and Employee Performance

Variables	Descriptive Statistics						
	N Statistic	Mean Statistic	Std. Dev Statistic	Skewness Statistic	Std. Error	Kurtosis Statistic	Std. Error
Employees are involved in goal setting during performance management system process.	130	2.9154	1.40340	.016	.212	-1.400	.422
Constant supervision by our immediate supervisor; is a good technique to encourage employees to perform well.	130	3.4077	1.22440	-.671	.212	-.609	.422
There is a link between the current performance and employee goals in the organization	128	3.1016	.97883	-.565	.214	-.821	.425
There are performance targets for the employees set by their supervisor	128	3.2422	1.22793	-.423	.214	-.944	.425
Effective Customer service delivery is used to measure the level of employee Performance.	128	2.9219	1.18128	-.313	.214	-1.108	.425
Reduced number of complaints is used to measure the level of employee Performance	128	2.9766	1.18032	-.188	.214	-1.112	.425

Source: Field data (2020)

on whether there was effective customer service delivery used to measure the level of employee performance had a mean of 2.9219 with standard deviation of 1.18128, with skewness of -0.313 and kurtosis of -1.108 and on the question whether there was reduced number of complaints used to measure the level of employee performance

had the mean of 2.9766 with standard deviation of 1.18032 with skewness of -0.188 and kurtosis of -1.112. The views from the respondents varied on the questions asked on performance planning system and employee performance of the Kenya Meat Commission.

Descriptive Statistics of Performance Appraisal System and Employee Performance

The second objective of the study was to establish the influence of performance appraisal system on employee performance of Kenya Meat Commission. The results of descriptive statistics were as shown in Table 3. There were seven (7) questions asked on the performance appraisal system on employee performance. The question on whether performance appraisals were done yearly in the organization had the mean of 3.2636 with standard deviation of 1.30216 with skewness of -0.374 and kurtosis of -1.077; on whether KMC has a good performance appraisal system had the mean of 3.5625 with standard deviation of 0.95365 with skewness of -0.735 and kurtosis of 0.234; on the question whether the organization gives emphasis to workers development through training had the mean of 3.2538 with standard deviation of 1.09482 with skewness of -0.773 and kurtosis of -0.327; on whether training needs are identified through performance appraisal had a mean of 2.715 with standard deviation of 1.1291 with skewness of 0.188 and kurtosis of -0.966;

Table 3: Descriptive Statistics of Performance Appraisal System and Employee Performance

Variables	N Statistic	Descriptive Statistics		Skewness		Kurtosis	
		Mean Statistic	Std. Deviation Statistic	Statistic	Std. Error	Statistic	Std. Error
Performance appraisals are done yearly in the organization	129	3.2636	1.30216	-.374	.213	-1.077	.423
KMC has a good performance appraisal system	128	3.5625	.95365	-.735	.214	.234	.425
The organization gives emphasis to workers development through training.	130	3.2538	1.09482	-.773	.212	-.327	.422
Training needs are identified through performance appraisal	130	2.715	1.1291	.188	.212	-.966	.422
Supervisors give employees feedback when appraised	130	2.7923	1.22440	.020	.212	-1.089	.422
Employee performance feedback promotes service delivery	130	3.0615	1.32802	-.215	.212	-1.164	.422
Appraisal feedback improves communication in your work place	130	3.6923	3.78255	9.476	.212	101.692	.422

Source: Field data (2020)

on whether supervisors gave employees feedback when appraised had a mean of 2.7923 with standard deviation of 1.22440 with skewness of 0.020 and kurtosis of -1.089; on the question whether employee performance feedback promotes service delivery had the mean of 3.0615 with standard deviation of 1.32802 with skewness of -0.215 and kurtosis of -1.164 and on whether appraisal feedback improves communication in your work place had a mean of 3.6923 with standard deviation of 3.78255 with skewness of 9.476 and kurtosis of 101.692. Generally, the views from the respondents vary on the variables of performance appraisal system on employee performance of Kenya Meat Commission as depicted by the standard deviations and the means.

Descriptive Statistics of Employee Performance

The study also established the descriptive statistics on employee performance of Kenya Meat Commission.

Table 4: Descriptive Statistics of Employee Performance

Variables	N Statistic	Descriptive Statistics		Skewness		Kurtosis	
		Mean Statistic	Std. Deviation Statistic	Statistic	Std. Error	Statistic	Std. Error
Work targets are met/accomplished	130	3.3538	2.88772	9.370	.212	99.983	.422
Organizational career development enhances employee commitment and hence employee performance	130	2.8385	1.01006	.102	.212	-.708	.422
The current level of employee performance is high	129	2.5814	1.24811	.106	.213	-1.278	.423
The current employee strategies have enhanced promptness in meeting work deadlines	130	2.7692	1.00030	.102	.212	-1.040	.422
I meet the expected deadlines for submission of work	129	3.2403	1.13037	-.224	.213	-.980	.423
Employees find satisfaction in executing their duties and they endeavor to satisfy their customers daily	130	3.5923	1.03950	-1.091	.212	.716	.422

Source: Field data (2020)

There were six (6) questions on employee performance of Kenya Meat Commission and their results were as shown in the Table 4. The question on whether work targets were met/accomplished had a mean of 3.3538 with standard deviation of 2.88772 with skewness of 9.370 and kurtosis of 99.983; on whether organizational career development enhances employee commitment and hence employee performance had a mean of 2.8385 with standard deviation of 1.01006 with skewness of 0.102 and kurtosis of -0.708; on the question asked whether the current level of employee performance is high had a mean of 2.5814 with standard deviation of 1.24811 with skewness of 0.106 and kurtosis of -1.278; on whether the current employee strategies have enhanced promptness in meeting work deadlines had a mean of 2.7692 with standard deviation of 1.00030 with skewness of 0.102 and kurtosis of -1.040; on whether the respondent is able to meet the expected deadlines for submission of work had a mean of 3.2403 with standard deviation of 1.13037 with skewness of -0.224 and kurtosis of -0.980 and on whether employees find satisfaction in executing their duties and they endeavor to satisfy their customers daily had a mean of 3.5923 with standard deviation of 1.03950 with skewness of -1.091 and kurtosis of 0.716. The views from the respondents varied on the questions asked on the employee performance of the Kenya Meat Commission.

Relationship between Performance Planning System and Employee Performance

Inferential statistics, especially regression analysis was conducted to establish the relationship between performance planning system and employee performance in the Kenya Meat Commission. The results were as shown in Table 5. In the regression analysis, beta (β) coefficient is the degree of change in the outcome variable (employee performance) for every 1-unit of change in the predictor variable. R is the correlation coefficient; R-squared (R^2) is the coefficient of determination which explains the percentage of variance in the outcome variable that is explained by the independent variable(s); F-value explains a significant amount of variance in the

dependent variable (employee performance); t-test assesses whether the beta coefficient is significantly different from zero. If the beta coefficient is not statistically significant (that is, the t-value is not significant).

Table 5: Regression Results of Performance Planning System and Employee Performance
Model Summary

R		Adjusted R Square	Std. Error of the Estimate	R Square Change	Change Statistics			Sig. F Change
R	R Square				F Change	df1	df2	
0.533 ^a	0.284	0.278	0.74175	0.284	50.777	1	128	0.000
		ANOVA		Mean Square	F	Sig.		
		Sum of Squares	df					
Regression		27.937	1	27.937	50.777			0.000 ^b
Residual		70.424	128	.550				
Total		98.361	129					
Model		Unstandardized Coefficients		Standardized Coefficients	t	Sig.	95.0% Confidence Interval for β	
		B	Std. Error	Beta			Lower Bound	Upper Bound
1	(Constant)	1.773	0.193		9.201	0.000	1.392	2.154
	OBJ1	0.398	0.056	0.533	7.126	0.000	0.287	0.508

a. Dependent Variable: Employee performance of Kenya Meat Commission

b. Independent Variable: Performance planning system

Significance level ≤ 0.05

Source: Field data (2020)

Regression coefficient (B), beta (β) coefficient, analysis of variance (ANOVA) and t-test were used to test the hypothesis at 0.05 % significance level, with 95% confidence interval, which is acceptable in social sciences. The first study tested the following null hypothesis:

H₀₁: Performance planning system has no significant influence on employee performance in Kenya Meat Commission.

Results showed that performance planning system had a positive, linear and significant (p-value is less than 0.05) effect on the employee performance of Kenya Meat Commission {regression coefficient, $\beta=0.398$, correlation coefficient, $R=0.533$, beta= 0.533 , ANOVA, $F(1,128)=50.777$ and t-test value, $t=7.126$ }. The results illustrated that there was a statistically significant positive relationship between performance planning system and employee performance of Kenya Meat Commission. Performance planning system explained 28.4% ($R^2 = 0.284$) variations in the employee performance of Kenya Meat Commission.

The test criterion was set such the study rejects the null hypothesis H₀₁ if $\beta_1 \neq 0$. Regression results were achieved when the variables of performance planning system were regressed with mean of employee performance of the Kenya Meat Commission. The results are represented in the following model:

$$Y = \beta_0 + \beta_1 X_1 + \epsilon$$

Where Y= Employee performance ,

$\beta_0 = 1.773$ (constant)

$$\beta_1 = 0.398$$

X_1 = performance planning system

ε =

Replacing in the equation above, the model becomes:

$$Y = 1.773 + 0.398X_1 \dots \dots \dots \text{Eq. 1}$$

In the test criterion, the null hypothesis was accepted when the p-value is more than 5% (0.05) and the null hypothesis is rejected when the p-value is less than 0.05. From these results, the null hypothesis was rejected since a positive, linear and significant (p-value is less than 0.05) relationship was established between performance planning system and employee performance of the Kenya Meat Commission. These findings were in agreement with past studies. A study conducted in Nigeria by Esu & Inyang (2009) on a case for performance management in the public sector. Performance management is a comprehensive approach for planning and sustaining improvements in the performance of employees and teams, so as to meet standards. In the public sector, annual budgets and annual performance evaluations are used in managing performance-outcomes and behavior. These two deal with the past and not futuristic. The absence of PMS has contributed to the high rate of business failures in the public sector. The adoption of PMS will make public business effective, efficient and sustainable. This will turnaround the Nigerian public sector and enables it to achieve the national goals and remain an influential institution as “an instrument of public service delivery and development.”

In Kenya, Owino *et al.*, (2019) did a study on influence of performance management systems on employee productivity in County Referral Hospitals in Kiambu County-Kenya. This study adopted a descriptive a descriptive cross sectional research design on determining the influence of performance management systems on employee productivity in county referral hospitals operating in Kiambu County. The variables under review included were planning, and appraisal. The study employed stratified sampling technique to get a sample size of hundred and ten individuals for purposes of collecting data. The study used questionnaires as data collection instruments. The study variables were found to be having a statistical significant impact on employee productivity. The regression analysis showed that planning $\beta_1 = .130$, $P = .159$ and appraisal $\beta_2 = .129$, $P = .203$, which were found to have an insignificant effect in determining employee productivity. The study recommended that there is need for the organizations to set realistic goals, organizing regular review discussions in regards to employee performance.

Inferential Statistics of Performance Appraisal System and Employee Performance

This was the second objective. Table 6 gave results on the performance appraisal system and Employee performance of the Kenya Meat Commission. Inferential statistics results of the performance appraisal system and employee performance of the Kenya Meat Commission were as shown in Table 6. These results were achieved when the mean performance appraisal system was regressed with the mean of employee performance of the Kenya Meat Commission. The following was the second null hypothesis:

H_{02} : Performance appraisal system has no significant influence on the employee performance in Kenya Meat Commission.

Table 6: Regression Results of Performance Appraisal System and Employee Performance

Model Summary								
					Change Statistics			
R	R Square	Adjusted R Square	Std. Error of the Estimate	R Square Change	F Change	df1	df2	Sig. F Change
0.494 ^a	0.244	-0.238	-0.76238	-0.244	41.232	1	128	0.000
ANOVA								
		Sum of Squares	df	Mean Square	F	Sig.		
Regression		23.965	1	23.965	41.232	0.000 ^b		
Residual		74.396	128	0.581				
Total		98.361	129					
Coefficients ^a								
Model	Unstandardized Coefficients		Standardized Coefficients	t	Sig.	95.0% Confidence Interval for β		
	B	Std. Error	Beta			Lower Bound	Upper Bound	
(Constant)	1.650	0.230		7.165	0.000	1.194	2.106	
Performance appraisal system	0.443	0.069	0.494	6.421	0.000	0.307	0.580	

a. Dependent Variable: Employee performance of Kenya Meat Commission

b. Independent Variable: Performance appraisal system ; Significance level ≤ 0.05

Source: Field data (2019)

Model summary results illustrated that when performance appraisal system was regressed with employee performance of Kenya Meat Commission had R-Square of 0.244 which indicated the percentage (24.4%) of variance in the employee performance of Kenya Meat Commission that is explained by performance appraisal system. $F(1,128)=41.232$ explains a significant ($p \leq 0.05$) amount of significance difference in the employee performance of Kenya Meat Commission and a unit change of 0.494 in the employee performance of Kenya Meat Commission was attributed to a unit change in the performance appraisal system. Results illustrated that there was a statistically significant ($p \leq 0.05$) positive relationship between performance appraisal system on employee performance of Kenya Meat Commission (regression coefficient, $\beta=0.443$, beta=0.494, $R=0.494$ and t-test value, $t=6.421$).

The test model is as follows: $Y = \beta_0 + \beta_2 X_2 + \epsilon$

Whereby Y = employee performance of Kenya Meat Commission, X_2 = performance appraisal system, β_0 = constant, β_2 is coefficients of regression and ϵ is the standard error.

Replacing in the equation above, the model becomes:

$$Y = 1.650 + 0.443X_2 \dots \dots \dots \text{Eq. 2}$$

From the results in Table 6, the null hypothesis was rejected since a positive, linear and significant (p-value was less than 0.05) was established between performance appraisal system and employee performance of Kenya

Meat Commission. These findings are in agreement with other studies on performance appraisal system and employee performance of Kenya Meat Commission. In Nigeria, an empirical study conducted by Abdulkadir *et al.*, (2012) on the effects of strategic performance appraisal, career planning and employee participation on organizational commitment. This study adopted a descriptive survey among fourteen Nigerian banks. The study employed G-test, regression analysis and correlation analysis in testing the hypotheses. The study findings revealed that performance appraisal system, career planning systems and employee participation had a significant influence on employee job commitment and the level of organization commitment of employees in the Nigerian Banking industry is quite low. The study recommended that workers needs to be committed to their works. Employees should make conscious efforts towards strategically managing performance appraisal, career planning and employee participation with an objective of ensuring the desired results remain realistic and attainable.

Research done by Kariuki (2014) indicates that performance appraisal is considered to be an occasional assessment of an employee's work by measuring it against the activity's expressed or assumed prerequisites. He states that performance appraisal has been connected to representative inspiration and adequacy in terms of service delivery. Moreover, it assumes a significant job in employees' level of satisfaction and this creates inspiration, and commitment towards the employer. Research gap exists in countries like Kenya, on the significance of performance evaluation and its real impact on an organization so to reveal that hole we are finding the effect of performance appraisal on workers' duty in the government sector.

CONCLUSIONS AND RECOMMENDATIONS

The following were conclusions of the study derived from the summary of the study:

Results illustrated that there was a statistically significant positive relationship between performance planning system and employee performance of Kenya Meat Commission and that performance planning system explained 28.4% ($R^2 = 0.284$) variations in the employee performance of Kenya Meat Commission. Results illustrated that there was a statistically significant ($p \leq 0.05$) positive relationship between performance appraisal system on employee performance of Kenya Meat Commission and that 24.4% of variance in the employee performance of Kenya Meat Commission that is explained by performance appraisal system.

The following were the recommendations of the study:

- The management of the Kenya Meat Commission should invest more in the performance management systems (performance planning system, and performance appraisal system) which has been established to have had a positive effect on the employee performance.
- The Kenya Meat Commission should strengthen their performance appraisal systems ensure they are operational since they have been proved to improve employee performance. The research is recommended for further research to be conducted in other sectors in Kenya to ascertain if consistent results can be achieved.

REFERENCES

- Abdulkadir, D. S., Isiaka, S. B., & Adedoyin, S. I. (2012). Effects of strategic performance appraisal, career planning and employee participation on organizational commitment: An empirical study. *International Business Research*, 5(4), 124.
- Aguinis, H. (2019). Performance Management. *Chicago Business Press* .
- Al-Alawi, A. (2018). PERFORMANCE OF ONLINE BANKING: CULTIVATING STRATEGIC MODEL MAP IN FINANCIAL SECTOR-CASE OF BAHRAIN. *Journal of Internet Banking and Commerce* .
- Armstrong, M. (2009). *Handbookbook of Performance Management*. Philadelphia: ISBN 978 0 7494 5392 3.

- Assish, J. (2018, March). Factors That Influence the Effectiveness of Performance Management System Adoption in Organisation. *Global Journal of Human Resource Management* , pp. 51-66.
- ASWANI, J. O. (2018). Effect Of Performance Measurement On . *Doctor Of Philosophy* .
- Aswani, J. O. (2018). Effect of Performance Measurement on Employee Engagement in. *Thesis Submitted in Partial Fulfillment for the Degree of Doctor* .
- Bhattacharya, A. (2016). Expectacy Theory of Performance Management System. *Project Guru* .
- Bullah, L. N. (2016). Influence Of Human Resource Strategies On Employee. *A Research Project* .
- Buuri. (2015). Performance Measurement Practices and Employee Productivity in the Insurance Firms in Kenya. *A Research Project Submitted In Partial Fulfillment Of The Requirements For The Award Of The Degree Of Master Of Business And Administration (Mba Degree), School Of Business University Of Nairobi*.
- Chebet, W. (2015). *The Relationship Between Performance Contracting And Organization Performance In National Hospital Insurance Fund*. Nairobi: School Of Business, University Of Nairobi.
- GoK. (2018). Performance Contract between the Government of Kenya and Kenya Meat Commission. *Performance Contract* .
- Haye, A. (2019, April 30). Management by Objectives . *Business Essentials* .
- Hearn, S. (2017, August 28). Explaining the Stages of the Performance Management Cycle. *Clear Review* .
- Imenda, S. (2014). Is There a Conceptual Difference between Theoretical and Conceptual Frameworks? *Theoretica versus Conceptual Frameworks* .
- Islami, X. (2018). Using Management by Objectives as a performance appraisal tool for employee satisfaction. *Future Business Journal* .
- Jenifa, M. (2014). *THE IMPACT OF PERFORMANCE MANAGEMENT SYSTEMS*. ARUSHA: OPEN UNIVERSITY OF TANZANIA.
- Jugmohun, A. (2018). Factors That Influence The Effectiveness Of Performance Management System Adoption In Organisation. *Global Journal of Human Resource Management* .
- Kamencu, S. M. (Vol 2, No 3, 2011, November 3). The Effect of Performance Appraisal Systems on Employees in Kenya Tea Development Agency: A Survey of Selected Tea Factories in Meru County-Kenya. *Research Journal of Finance and Accounting* , p. 23.
- Kariuki, R. W. (2014). Effect Of Performance Appraisal On Employees' Performance In Barclays Bank Of Kenya. *Graduate Studies ,Kca University* .
- Kobia, O. (2016). Performance Rewards and Sanctions Framework for the Public Service Government of Kenya. *GoK* .
- Munguti, B. K. (2017, November 21). *International Academic Journal of Human Resource and Business Administration* .
- Munywoki, S. K. (2015). Performance Management Systems Strategy And Employee Commitment At Kenya Commercial Bank Group, Thika Branch, Kenya. Thika.
- MUTHINA, N. F. (2017). Performance Of Commercial State Corporations In Kenya.

- Ochieng, E. O. (2015). The Effect Of Performance Management Practices On Employee Productivity: A Case Study Of Schindler Limited. *United States International university-Africa* .
- Ondieki, K. M. (2017). The Effect Of The Balanced Scorecard On Organizational Performance In The Public Sector In Kenya: A Case Of Kenya Bureau Of Standards .
- Osewe, J. O. (2019, 7 1). Balanced Scorecard Adoption Rationale and Organizational Performance of State Corporations in Kenya. *College of Human Resource Development-Digital Respository* .
- Pulakos, E. D. (2004). *Performance management. A roadmap for developing*.. Society for Human Resource Management.
- Raphael, H. N. (2018). Performance Management and Employees' Engagement in Selected Brewery Firms in the South-East Nigeria. *European Journal of Business and Management* .
- Saleem, H. (2015, Nov). Impact of performance appraisal on job satisfaction in banking sector of Pakistan. . *International Journal of Management Sciences and Business Research* .
- Sarisar, J. O. (2013, November 2). Concept of performance contracting –Kenyan scenario/experience. *Developing Country Studies* .
- Serra, e. a. (2017). Application Of Goal Setting Theory. *Global Business Research Congress (GBRC)* .
- Sila, N. N. (2018, July 7). Determinants Of Implementation Of Performance Contracting: Makueni County Government, Kenya. *International Journal of Economics, Commerce and Management* .
- Strategicplan. (2015). Strategic plan 2015-2019.
- Wanga, J. W. (2018). Effect of Balanaced score Card on Performance of Kenya Ports Authority. *UoN Repository* .
- Ziyaminyana, N. (2019). An Investigation into the Impact of Performance Management. Systems on Employee Productivity: The Case Study of Information and Communication Technologies (ICT) Companies. *European Journal of Business and Management* .