

Effect of Mobile Phone Transfer Services on Performance of Micro and Small Enterprises: A Case of Trans-Nzoia County, Kenya

Kirigano B. Makee

Private Bag Moi's Bridge - 30202 Kenya

E-mail: bkirigano@yahoo.com

Dr. Muturi Willy

Senior Lecturer, Jomo Kenyatta University of Agriculture and Technology, P. O. Box 62000-00200, Nairobi, Kenya, School for Human Resource Development Entrepreneurship and

Procurement Department

E-mail: willymuturi2006@yahoo.com

Fred G. Atandi

Lecturer, Jomo Kenyatta University of Agriculture and Technology, P. O. Box 62000-00200, Nairobi, Kenya, School for Human Resource Development Entrepreneurship and Procurement Department

E-mail: fredatandi06@yahoo.com

DOI: 10.6007/IJARBSS/v4-i11/1276 URL: <http://dx.doi.org/10.6007/IJARBSS/v4-i11/1276>

Abstract

Over the last few years, small and micro enterprise owners have innovatively responded to changing market dynamics by adopting innovations in their firms aimed at maximizing on their returns as they minimize costs. Mobile-phone banking, Mobile payments commonly known as "Lipa na M-pesa" and Agent banking for instance are common aspects of these firms. However, the effect this adoption has had on their performance has remained unclear. This is what this study sought to find out. The study sought to analyze the effect of mobile phone transfer applications on performance trends of micro and small enterprises. The sampling frame constituted all micro and small enterprises found in the hair-dressing, carpentry and cloth-making industries in Kitale town. They were estimated at 500 according to county government revenue data. Simple random sampling was used. A list of all the 500 enterprises was compiled; the researcher then made use of random number tables to generate the sample. This was best achieved by the researcher blindly picking a number in the table of random numbers, and then progressed in a random way considering numbers 001 to 500; until a sample of 110 was achieved. A questionnaire was prepared using 1 to 5 point likert scale; with 5 as strongly agree

to 1 strongly disagree. The survey was carried out between July 10th and August 5th 2014 in Kitale town. Of the micro and small enterprises surveyed, 68 admitted to using the innovations, 30 did not use any of the innovations while 12 did not fill the questionnaire. Mobile phone applications were the mostly used with 46 (65.7%) of those surveyed admitting that they use them in their business, 2 (2.9%) of those surveyed said they use Agent banking while 3 (3.1%) applied M-banking; 9 (12.9%) applied all the three innovations mentioned. A sizeable group 10 (14.3%) said they used other innovations not listed for instance internet applications to get the latest fashion trends. The respondent expressed their views with 5 (strongly agree) to 1 (strongly disagree). Completed questionnaire was then collected for coding and analysis. Descriptive and statistical analysis was carried out from which the researcher was able to compute the Pearson product moment correlation (r) to establish relationship. The study revealed that there is indeed an effect of the mobile phone transfer services innovations on enterprise performance. Of the 66.3% of enterprises surveyed, did indicate that when innovations are used they help bring more customers leading to more business income, 69.4% indicated that the innovations save time and money while 59.2% observed that the innovations contributed to their profits and that the more they invested in them the more the profits. Based on the findings, the study recommends a tax waiver on all mobile phones and related paraphernalia to enable majority apply them even in enterprises. Entrepreneurship policies on the other hand should be well researched before implementation to guarantee sustainability.

Keywords: Mobile phone transfer services, Micro and Small Enterprises, Enterprise performance.

1.0 Introduction

The agrarian revolution ushered a new era in the history of mankind; the transformation from hunting and gathering to growing of crops and rearing of animals. Man consciously or unconsciously became innovative to sustain the new order. Agriculture in particular influenced scientific and technological knowledge and skills. Farmers had to invent tools for digging and clearing the bushes; they also had to learn how to interpret weather patterns so as to know when the rains or floods would come. Early farmers learnt geometry to help divide their land; while the knowledge of arithmetic was equally useful in counting seasons and recording farm produce. The invention of arithmetic and the calendar was for similar reasons, Kirithu, Kapiyo and Muna (2003).

Innovation economists Joseph Schumpeter looks at innovation as the application of better solutions that meet new requirements, unarticulated needs or existing market needs. This according to him is accomplished through more effective products, processes, services, technologies or ideas that are readily available to markets, governments or societies. He argues that industries must incessantly revolutionize their economic structure from within, that is innovate with better or more effective processes and products such as the connection from craft shop to factory. Recent research findings highlight the complementary role of organizations to translate innovative activity into tangible performance improvements by say providing their employees opportunities and resources to innovate, in addition to their core job tasks. All organizations have capacity to innovate including hospitals, schools, county governments and so on.

1.2 Statement Of The Problem

Small and micro enterprise owners have adopted digital innovations over the last few years with the intention of maximizing returns on their investments. In Kenya today, mobile phone payment services which include cashless distribution where fast moving consumer goods (FMCG) companies are now using M-pesa buy goods payment scheme for their distribution networks. Person to person (P2P) money transfers, cash in deposits and cash out withdrawals at M-pesa agents, consumer to business (C2B) payments, business to consumer (B2C) payments and international money transfers are a common aspect of many businesses. However, the effect these innovations have had on the performance of these enterprises is not clear. This is what this study sought to find out.

1.3 Research Objective

To evaluate the effect of Mobile phone transfer service applications on profitability of small and micro enterprises in Trans-Nzoia County, Kenya

1.4 Justification Of The Study;

A 2010 World Bank report shows that traditional sectors in Kenya key among them farming and tourism are slowly drying up. The global financier is betting on investments in the mining sector to propel Kenya to the next development level. Modern services in ICT-related businesses are also highlighted as emerging growth drivers.

The Kenyan government on her part; share the view that innovative approaches to operations is what will ultimately unlock our trapped potential and catapult the country towards vision 2030 particularly through digitizing educational, the formal and the informal sectors. This as maybe true; a number of scholars and opinion leaders are of the contrary opinion. To them; digital innovations are necessary but not sufficient for the country's growth differential considering her infrastructural vulnerabilities.

This dilemma is also evident at the micro-level where individual small and micro-enterprises are indifferent as to whether marshalling resources towards digital technology integration in their businesses is actually viable. It is hoped therefore that this piece of research work will show case and provide answers to this technical dilemma. It is the researcher's belief that the small and micro enterprises will make informed decisions. Similarly; policy makers, economists and even scholars will have a base in their daily decision making process.

2.0 Theoretical Frameworks

This study was guided by diffusion of innovation theory, the technical determinism theory, the Social constructivism theory and the actor net work theories.

2.1 The Diffusion Of Innovations (DOI) Theory

Diffusion of innovation theory was advanced by Everret Rogers as a general diffusion model in 1962; although research in the area was initiated earlier in 1940s and 50s by different researchers. Diffusion theory provides tools, both quantitative and qualitative for assessing the likely rate of diffusion of a technology and additionally identifies numerous factors that facilitate or hinder technology adoption and implementation.

According to Rogers; Innovations possess certain characteristics; relative advantage, compatibility, complexity, trialability and observability which determine the ultimate rate and pattern of adoption. Some potential adopters are more innovative than others and can be identified as such by their personal characteristics; cosmopolitanism, level of education and so on. The adoption decision unfolds as a series of stages; from knowledge of the innovation through persuasion, decision, implementation and confirmation. The actions of certain kinds of individuals, opinion leaders and change agents can accelerate adoption.

The diffusion process usually starts out among pioneering adopters, reaches “take-off” as a growing community of adopters is established and the effect of kick in, and levels off as the population of potential adopters become exhausted. Innovators are usually a tiny number of visionary, imaginative and creative individuals who spent great time and energy on developing new ideas and gadgets. Early adopters on the other hand are those on the lookout for strategic leap forward in their lives or businesses and are quick to make connections between clever innovators and their personal needs. Their natural desire to be trend setters causes the “take-off” of an innovation. They become an independent test bed, ironing out the chinks and reinventing the innovation to suit mainstream needs.

Early majorities are pragmatists, comfortable with moderately progressive ideas and will not act without solid proof of benefits. They are cost sensitive and risk averse and always looking for simple, proven, better ways of doing what they already do and that they require guaranteed off-the-shelf performance, minimum disruption, minimum commitment of time, minimum learning and either cost neutrality or rapid payback periods. Late majority are conservative pragmatists who hate risk and are uncomfortable with new ideas. Their only driver is the fear of not fitting in and hence tries to follow mainstream fashions and established standards. Meanwhile laggards hold out to the bitter end; they see a high risk in adopting a particular product or behavior.

Rogers went ahead to the extent of assigning precise notional percentages for each segment as illustrated in figure 2.1

Figure 2.1 Propensity to adopt new innovations by various segments of a population

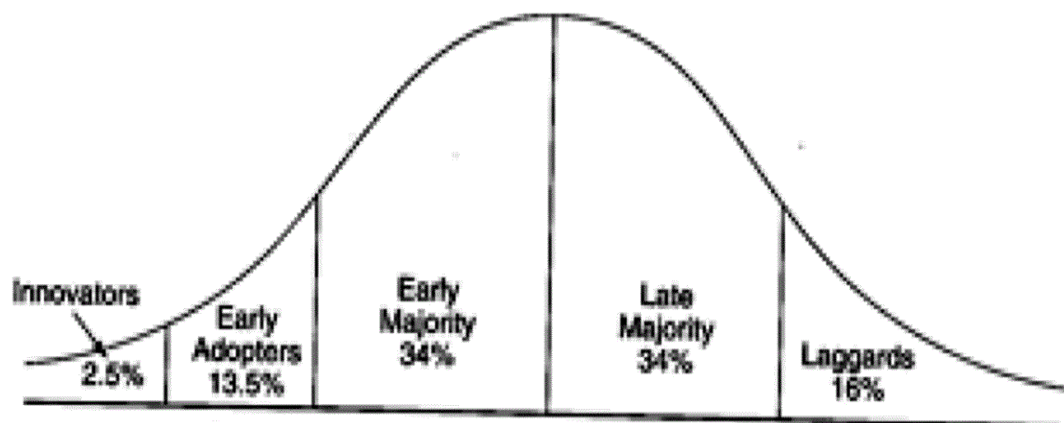

Source; Everett Rogers Diffusion of innovation model.

This theory holds even in societies where the technology originates. Rogers demonstrates adoption resistance using the example of Captain Lancaster's discovery and use of lemon juice for scurvy prevention in sailing ships in 1601. But in as much as the captain's discovery that lemon juice lowered the mortality rate of sailors, it was not until 1747, almost one and a half century later, that the British navy finally adopted the practice.

However, not all innovations in all communities take long periods of time to be adopted. Some innovations diffuse from first introduction and are widely used in a few years, at least in some societies; depending on how compatible the innovation is with existing societal norms and the benefits and ease with which it can be adopted. A case in question is the fast adoption of the internet by the Americans; Rogers (2003) found that 71% of adult Americans had adopted the internet in just a dozen years (1989-2002). Mobile phones and their associated technologies like money transfer technology have also diffused very rapidly in developing countries where they have overtaken many older technologies like money orders, fax, landlines etc.

The theory provides a broad framework for the study of organizational factors affecting the adoption of business tools, including e-business and e-technologies Minish-Majanja and Kaplang'at (2005,). It has also been applied in a wide variety of situations that involve the uptake of innovations, including the use of ICTs (Harris, 2002, p.7). The quick pace at which mobile phone technologies was adopted in Kenya meets three of the five criteria of diffusion of innovations theory, namely relative advantage, compatibility and complexity. With respect to relative advantage; mobile phone and mobile transfer services by SME traders has delivered more advantages than other methods of communication in receiving and sending information from and to suppliers, customers, friends and relatives. On complexity; mobile phones in comparison to computers do not require high literacy levels and are also readily available due to their relative affordability. Kuuya (2010) found in his research in the informal sector in Kenya; cost, societal norms and the environment as major considerations when adopting technology in the informal sector. The compatibility of the mobile phone has also helped it to diffuse rapidly in Kenyan society. Furthermore, the gadget has fitted well in Africa's oral culture.

2.2 The Technological Determinism Theory

This is a technology –led perspective of social change that looks at technology as the primary catalyst in history. One that is independent of human actions. The opposite perspective is the social constructivism approach which posits that technology is not neutral and is not designed and developed separately from politics, economics and power Oosteven (2007).

Technological determinism gives rise to the speculation that the adoption of technologies would enable developing countries to leapfrog many stages of development, facilitate poverty eradication, and catapult them into robust global economies Shamin (2007), Harison (2006), Koanantakou (2004) and Campaigne (2002) views technology diffusion as a challenge or means that can be used to build effective bridges, to integrate the three economies- the formal, informal and the global.

2.3 The Social Constructivism Theory

This entails a framework of theories that encompasses several progressive approaches. It posits that technology does not determine human actions, but rather human actions shape technology and that development of technology is a social process which does not take place in isolation

from society Oostveen, (2007). According to Oostveen, technological adoption in any society forms part of the socio-economic, political and cultural fiber of that society. The innovation is seen as a tool that can be used by the adopting society to perform existing tasks more efficiently or perform new tasks. The innovation is seen as playing a catalytic role rather than the central role in society Saffu and walker, (2008).

This theory is quite relevant to this study as it lays emphasis on the societal conditions as influencing the diffusion of innovations. The mobile phone technology for instance has not only diffused fast and widely but has been flexibly fashioned to provide mobile money services. The trend may be the exact opposite in Tanzania where mobile money services has not been taken up as fast as it was done in Kenya. This confirms that interpretive flexibility of artifacts and experiences can be understood and used in a variety of ways.

2.4 The Actor-Network Theory (ANT)

The theory was developed by Latour, Callon, and Law Callon,(2001). The theory places emphasis on both the social and technological actions who are involved in the development of technological systems and who are distinct entities for the maintenance of social order. The approach sees development of technology in terms of relationships formed between human and non-human elements in actor- networks. Actor Network Theory explains how all actors, starting with the technology itself, mobile phone providers, government policy makers, SME traders and other users have come together to perform the appropriate actions for the successful adoption of the technology in both the formal and informal sectors in Kenya since 2001.

2.5 Conceptual Framework

Independent variable

Digital Innovations

Dependent variable

Performance of MSEs

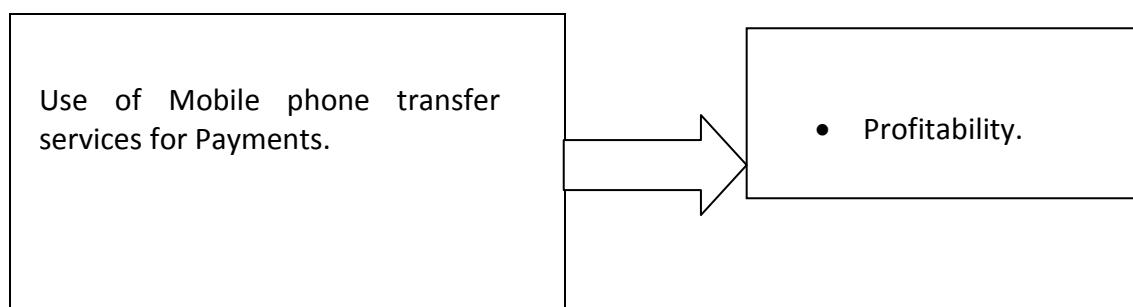

Fig 2.1 The Conceptual Framework.

2.5.1 Mobile Phone Payment Services

Safaricom's parent company Vodafone unveiled M-pesa in 2007. It debuted as a cheap, easy to use for millions of Kenyans unable to access a bank account or afford the hefty charges. The money transfer service grew quickly, capturing 17 million subscribers by December 2011 in the country. The initial concept was to create a service, which allowed small borrowers to conveniently receive and repay loans using safaricom's network of airtime resellers (currently float). This would enable micro-financiers to offer more competitive loan rates to their clients. Today, M-pesa is the most successful mobile money deployment on earth, boasting use by 51% of Kenya's adult population CCK, (2011).

Airtel on the other hand, ventured into the local mobile commerce business the same year (2007) under the Zap brand. With Airtel money service; one could do lots of things like shopping, pay bills, buy airtime, send money and also make payments for items purchased without using money or any credit or debit cards. The company has partnered with a number of organizations to allow users more convenient ways of accessing the services. In August 2011, Airtel re-launched Zap and renamed it Airtel money and opened up the service allowing customers to send money to any network in Kenya free of charge.

The use of mobile money transfer (MMT) service has continued to grow over time. According to CCK quarterly sector statistics report, by September 2012, total deposits on mobile platforms had increased from shillings 192 billion to shillings 205 billion with over 15.8 million customers who are supported by over 60,000 agent outlets countrywide. This growth indicates that the mobile money transfer service has become a key payments and transaction tool, mainly due to its easy use of applications, convenience and low cost value propositions (CCK report). This growth is despite protests by Kenya bankers association (KBA) who argued that low-end bank customers are protected against collapse of banks by the deposit protection fund (DPF) which refunds up to shillings 100,000 of the deposits in the event of collapse; a situation that may not be possible within the mobile transfer system.

According to the then Vodafone's director for mobile money, Michael Joseph, financial inclusion is fundamental human rights just like any other; and that there is a link between financial inclusion and poverty alleviation. M-shwari, to him therefore is an innovative new product that seeks to bridge the gap so that millions of Kenyans who cannot access formal financial services can save, earn interest and borrow money using their mobile phones. The game-changer being primarily aimed at the bottom of the pyramid; people who never bank, people who do not have bank accounts and people who struggle to get access to traditional banking. Cashless distribution-where fast moving consumer good (FMCG) companies are encouraged to start using M-pesa buy goods payment scheme for their distribution networks. FMCG distributors have nationwide coverage and have been receiving payments from their customers (bars, restaurants and other retail outlets) for goods delivered to them.

Person to person (P2P) money transfers allowing customers to send money from their m-pesa accounts to other M-pesa accounts. Cash in (deposits) and cash out (withdrawals) at M-pesa agents. Buy airtime for self and other safaricom subscribers. Pay bill/ consumer to business (C2B) payments-money transfers from subscribers to business –bills, utilities, insurance companies, buying goods& services and subscription payments. Bulk payments/ Business to consumer (B2C) payments- salaries, promotion payments, loan disbursements, dividend payments e.t.c. International money transfer –individuals receive money from abroad via M-

pesa services internationally to trade on a global scale regardless of and beyond their geographical and national boundaries.

2.5.2 Use Of Mobile Phone Transfer Services And Profitability

According to Vodafon's director for mobile money, Michael Joseph; financially inclusive societies create and unleash the potential for all to contribute to prosperity and stability. In a study of small and micro enterprises in the manufacturing industry in Canada, the introduction of e-business methods was found to explain 4% of sales growth and 5% of export performance Raymond, Bergeon & Bill (2005). They argue that whichever way one looks at it, whether profits are stepped up due to cost savings or profits are realized as a result of increased sales, the effect is notable.

2.6 Empirical Review

The global innovation index is one of the many research studies that try to build a ranking of countries related to innovation. Other indexes are the innovations indicator, innovation union scoreboard, EIU innovation ranking, BCG international innovation index, Global competitiveness report and the world competitiveness scoreboard. The global innovation index looks at both the business outcomes of innovations and government's ability to encourage and support innovations through public policy. The report discusses not only country's performance but also what businesses are doing and should be doing to spur innovation. It looks at new policy indicators for innovations, including tax incentives and policies for immigration, education and intellectual property. The latest index was made public in 2003; the study measured both innovation inputs and outputs. Innovation inputs included patents, technology transfer, research and development results, business performance such as labor productivity and total shareholder returns and impact of innovation on business.

Given the noticeable effects on efficiency, quality of life and productive growth, innovation is a key factor in society and economy. Consequently, policy makers have long worked to develop environments that will foster innovation and its resulting positive benefits; from funding research and development to supporting regulatory change, funding the development of innovation clusters and using public purchasing and standardization to "pull" innovation through.

In Kenya, the government has realized the important contribution of innovative technologies to economic growth. In this regard, the government through its ministry of information, communication and technology has embarked on an ambitious project of Konza city. It is envisaged that the city will be of its kind in Africa whose economy will be based on digital technology. It is anticipated that thousands of youths are likely to benefit from the massive job opportunities that are likely to be created. Telecom operators on the other hand will from July 2013 start remitting 0.5% of their total revenue to help fund universal access to ICT. The universal service fund (USF), established to increase access to ICT services in areas deemed not viable for investment by telecoms, is expected to start operations in July 2013 and targets at increasing mobile network coverage to entire country by 2030.

The money is to be used to put up infrastructure in areas that private sector firms in the industry have found to be uneconomical to invest in and to date remains underserved by

essential ICT services. Among the issues to be addressed include expanding the use of internet services in schools, health facilities and other organizations serving public needs. The priority areas were identified through the ICT gaps study done by CCK in 2011. Currently, more than 30 million Kenyans have access to cell phone services (75% penetration) while an estimated 14 million have access to internet (source; CCK). CCK on its own has funded putting up community centers aimed at providing access to affordable communication services and building ICT capacity. It is expected that this would significantly increase the number of people that have not had opportunity to interact with ICT as well as ease the burden for people who have to travel kilometers, sometimes up to 100 km, to get to a point where their cell phones could get a signal.

The Kenya national examinations council for example has evolved over the years. It is now quite possible for candidates to know their scores within minutes from the time they are released- thanks to innovative technologies, an exercise that could take days or even weeks a few years ago. This scenario is also evident in other sectors; communication, financial, education, manufacturing, to name but a few. Much as this may be the case, there has been heated debate in the country on the impact of these innovative technologies.

3.0 Methodology

Descriptive research design was made use of. The study gathered quantitative data which was used to explain the effect of mobile phone transfer services on performance of MSEs. Mugenda and Mugenda (1999) look at descriptive design as one that uses surveys to answer the problem statement in its current state. Questionnaire was used as research tool. Pilot studies were conducted to ascertain the validity and reliability of instruments. Both descriptive and inferential data analysis was carried out to analyze raw data. Statistical package for social sciences (SPSS) was used to process data. Regression was carried out to establish the relationship between the independent and dependent variables.

4.0 Research Findings And Discussion

This survey was carried out between July 10th and August 5th 2014. A total of 110 small and micro enterprises were surveyed in Kitale town. 68 admitted to using the innovations, 30 did not use any of the innovative strategies while 12 did not fill the questionnaire. Figure 4.1 gives the summary. Mobile phone applications were the mostly used, with 46(47%) of those surveyed admitting that they use them in their businesses, 2(2%) of those surveyed said they use agent banking, while 3(3%) applied M-banking, 9(9%) applied all the three innovations mentioned, 30(29%) did not use any innovations. A sizeable group 10(14.3%) said they used other innovations not listed for instance internet applications to get the latest fashion trends. Figure 4.1 shows the proportion of use

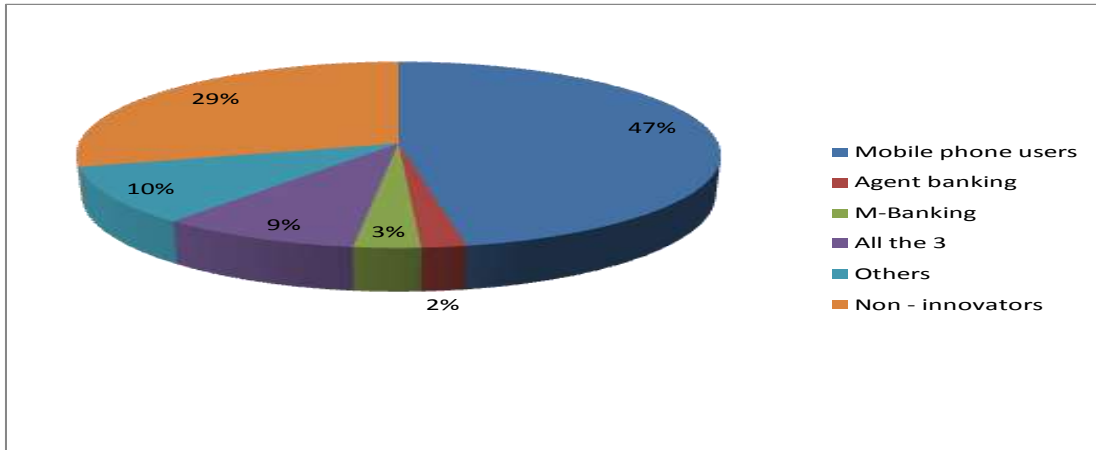

Figure 4.1 Proportion of use of various innovations

It was reported that 23(32.9%) of those surveyed said they use the innovations daily, 11(15.7%) said they use them once in a week, 24(34.35) indicated they use them twice a week, 5 (7.1%) use them when need arises.

4.2 Effect of mobile phones on performance of micro and small enterprises

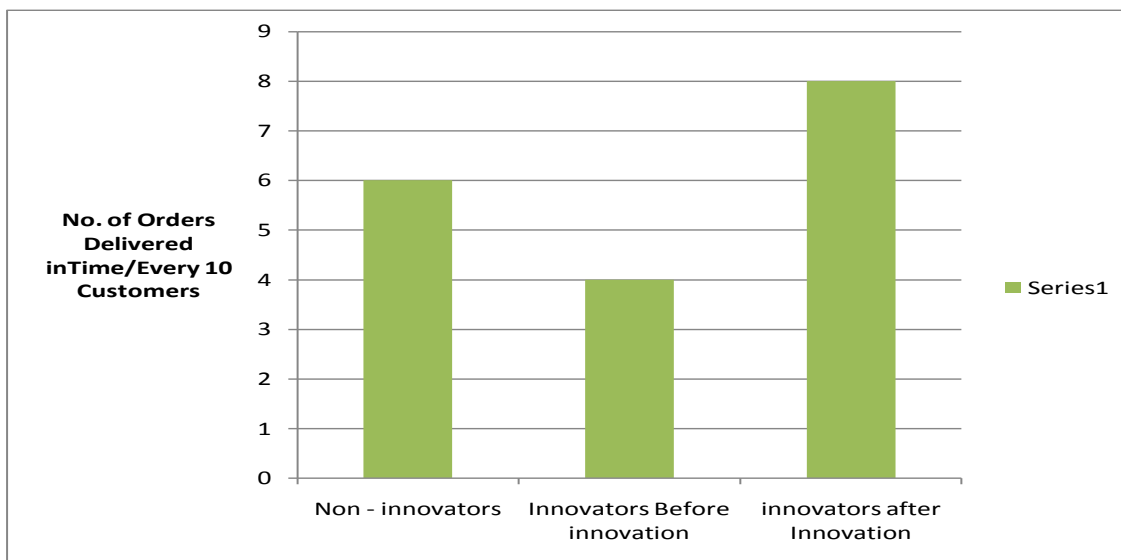

Figure 4.2 customer orders delivery rate (Mobile Phone users against non-innovators)

The study revealed that there is indeed an effect of mobile phone applications on profitability, number of customers served per time period as evidenced by the trend for the period July-December 2012 to January-June 2014.

Similarly, MSEs using mobile phones in their enterprises reported they can now be able to deliver 8 orders in time for every 10 customers served compared to only 4 that could be delivered in time before adopting the innovations. Those not applying any innovation reported to deliver 6 orders in time. MSEs applying innovations have an age over those not applying as depicted by the curves. This trend is also explained by a sizeable portion of those using the innovations who agree that they help bring more customers leading to more business income and that they bring business opportunities. They also save on time and money apart from facilitating access to more information through telephone contacts and internet and also being vital for business records and stock control. A new trend is also emerging where many of these MSEs use their phones to take photographs of their own output or products from elsewhere thereafter improving on them or even making stereotypes. Others even download new trends from the internet thereby making supernormal profits. There was a strong correlation between innovation use and profitability with $r = 0.63$ and p -value 0.041.

From the above discussions its evident that mobile phone applications were the frequently used innovation. 95.7% of those surveyed did indicate that the innovations fastens transactions and communications with customers, 88.6% said the innovations helps get supplies faster, 92.9% said the innovations bring business opportunities while 97.1% and 81.4% said they save time and money and aid in stock control and business records respectively.

5.0 Summary

This study was conducted between July 10th and August 5th 2014. 110 MSEs in Kitale town were surveyed. 68 admitted to using the innovations, 30 did not use any of the innovations while 12 did not fill the questionnaire. Mobile phone applications were the mostly used, with 46(65.7%) of those surveyed admitting that they use them in their business, 2(2.9%) of those surveyed said they use agent banking, while 3(3.1%) applied M-banking, 9(12.9%) applied all the three innovations. 10(14.3%) said they use other innovations not listed for instance internet applications to get the latest fashion trends. 23 (32.9%) of those surveyed said they use the innovations daily, 11 (15.7%) use them once a week, 24 (34.3%) indicated they use them twice a week, 5 (7.1%) use them once in a month while the rest 7 (10%) use them when need arises. The study revealed that there is indeed an effect of the innovations on profitability out of a number of customers served

5.1 Conclusion

The findings were based on a case of micro and small enterprises applying digital innovations in their enterprises together with those not applying. Hair, wood and textile industries were chosen due to their technical nature and it was easier to investigate the effect of the said innovations. There is a general trend that suggests indeed there is an effect of innovation use in the affirmative at 0.609. The time series trends show those using innovations in their business being in better positions than those not using. Other causative factors come into play and may

make it difficult to isolate the effect of innovation use on performance. Social cultural factors also come in, where despite the option of say paying digitally by “lipa na M-pesa”, many still struggle to do it manually, the benefits and convenience notwithstanding. From the survey, it is evident from the respondents that digital innovations cannot be wished away from the success of any business. In one way or the other, the innovations are at the center of most enterprises that are potentially on growth paths, the cutting line being the level of use. Most MSEs sampled use mobile phone applications with a few using M-banking or agent banking. The level of use is still at subsistence stage which limits any economies of scale that can be enjoyed by the said MSEs. Whichever way one looks at it, whether profits are stepped up due to cost savings or profits are realized as a result of increased sales, the effect is notable.

5.2 Recommendations

Based on the findings of this study, the following recommendations are made; this study recommends a reduction of tax on all digital gadgets; mobile phones and related technologies so that as many as possible can afford them and apply them even in enterprises. The youths on the other hand should be oriented with a broader mindset to see divergent economic avenues as alternatives to white color jobs.

The study further recommends development and nurturing of mobile phone applications as platforms not only for social networking but for enterprise development as well. Digital enterprise skills to be introduced at earlier levels of education cycle so that entrepreneurship and venture creation are not afterthoughts but predetermined career highways. Entrepreneurship skills should be taught, applied and tested. Many MSEs surveyed seem to be using trial and error as a means of achieving intended goals. The study finally recommends well researched policies particularly on entrepreneurship. The government right from independence has championed enterprise development as a quick fix to unemployment related challenges. Most government papers right from independence; the sessional paper number 10 of 1965 on African socialism, the sessional paper number 1 of 1986 on economic management for renewed growth, the sessional paper number 2 of 1992, the 2005 paper on economic recovery and even the current vision 2030; all of which seem to emphasize on venture creation through resource intervention without paying attention to skill and capacity needs. This study recommends entrepreneurship policy where the intervention is in form of skills and capacity.

5.3 Suggested Areas For Further Research

This study suggests an investigation of culture as a negating factor to innovation use. Why for instance people continue walking long distances to banks when they can conveniently bank using digital means. Why for instance people shy away from M-shwari loan facilities but go in for expensive ones given by micro-credit institutions.

Acknowledgement

I will like to appreciate the encouragement I received from my colleagues we studied together at master class of 2012 at Jomo Kenyatta University of Agriculture and Technology.

Thanks also to the lecturers for their guidance through the course of my study.

References

- Adam L. (1996). African connectivity problems, solutions and actions; some recommendations from Inet.
- Aker J. and Mbiti I. (2010). Mobile phones and economic development in Africa, working paper, from centre for global development.
- Albu M. and scott A(2001). Understanding livelihoods that involve micro-enterprises; markets and technological capabilities in the SL framework. Warwickshire; information technology development group(ITDG).
- Allen J. (2004). Redefining the network . Enrollment strategies in the PDA industry. Information technology and people.
- Ashrafi R. , Murtaza M. (2008). Use and impact of ICTs on SMEs in Oman. The electronic journal of information systems evaluation.
- Barbra Sanchez, Martinez Ruiz and Jimenez Zarco A(2007). Drivers, benefits and challenges of ICT adoption by small and medium sized enterprises (smes); a literature review, problems and perspectives in management .
- Campaigne J. (2002) Taking E-finance to the next level. Promotion of rural initiatives and development enterprises (PRIDE) Africa. Org/commerce/event docs/monetary/J campaign-pride Africa-EEfd.
- Castells M (1999). Information technology, globalization and social development; discussion paper(114).Geneva:Unitednations research institute for social development(UNRISD).
- Chew H., Ilavarasan P. and Levy R. (2010). The economic impact of information and