



KIBABII UNIVERSITY

UNIVERSITY EXAMINATIONS
2021/2022 ACADEMIC YEAR

THIRD YEAR FIRST SEMESTER
MAIN EXAMINATIONS

FOR THE DEGREE OF BACHELOR OF SCIENCE IN RENEWABLE
ENERGY AND BIO FUELS TECHNOLOGY

COURSE CODE: REN 313

COURSE TITLE: Bioenergy 1

DURATION: 2 HOURS

DATE: 18/05/2022

TIME: 9:00AM-11:00AM

INSTRUCTIONS TO CANDIDATES

- Answer **QUESTION ONE** (Compulsory) and any other **ONE (1)** Question.
- Indicate **answered questions** on the front cover.
- Start every question on a new page and make sure question's number is written on each page.

This paper consists of 7 printed pages. Please Turn Over



KIBU observes ZERO tolerance to examination cheating

Question One

- (a) Briefly describe the process of gasification [3 Marks]
- (b) What are the advantages of having gasification in energy conversion? [2 Marks]
- (c) Name two practical applications, where gasification is a part of the energy conversion process. [2 Marks]
- (d) Some of the features to improve the performance of traditional stoves include: [5 Marks]
- an enclosed/insulated fire to retain the heat;
 - careful design of pot holder to maximize the heat transfer from fire to pot;
 - baffles to create turbulence and hence improve heat transfer;
 - dampers to control and optimize the air flow;
 - a ceramic liner to minimize the rate of heat loss;
 - a grate to allow for a variety of fuel to be used and ash to be removed;
 - metal casing to give strength and durability;

Explain how ANY of the features listed above have been incorporated in the design shown below

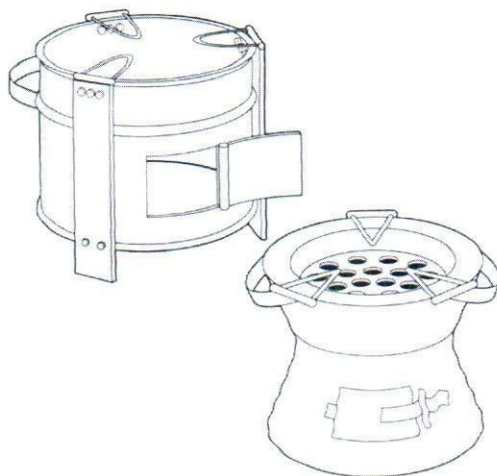

- (e) In the figure below, identify the conversion processes 1-7 [7 marks]

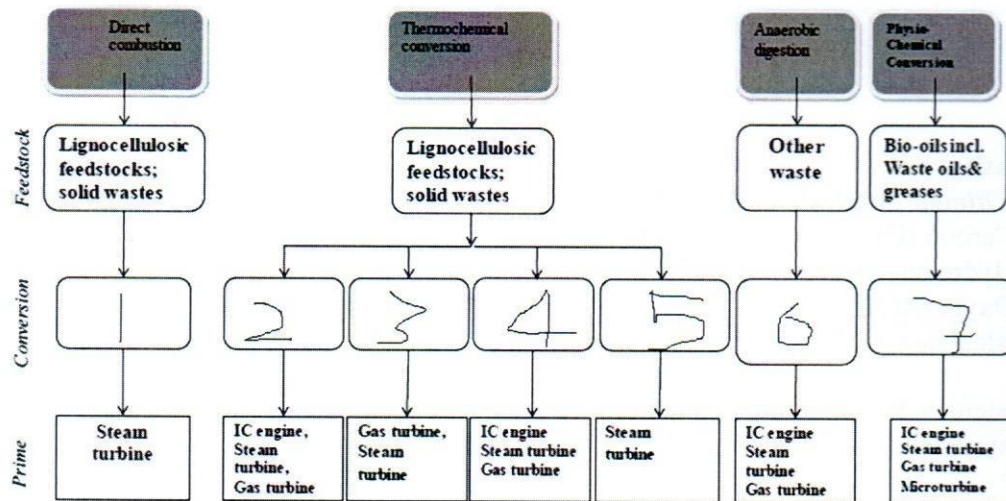

- (f) (i) With the aid of a sketch, explain the carbon cycle [5 Marks]
- (ii) Explain how bioenergy use can be “carbon-neutral” [5 Marks]

Question Two

In an industrial application 20 MW steam power (at 30 bar & 300°C) is produced using a wood fired biomass boiler. The schematic below shows the process of energy conversion in the biomass boiler. Wood fuel has the following property details.

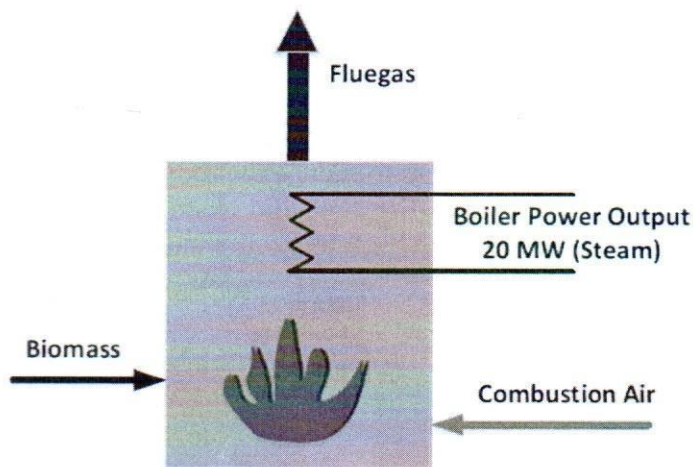

Table 1: - Proximate and Ultimate Analysis of Wood fuel use in combustion process *Proximate Analysis of Wood*

Volatiles	75%
Fixed Carbon	12%
Water	13%

Ash	0%
Ultimate Analysis of Wood fuel	
Carbon (C)	42%
Hydrogen (H)	5%
Oxygen (O)	40%

(a) Calculate the LHV of wood fuel [4 Marks]

(b) Calculate the fuel flow rate (kg/s) to the boiler (Assume the boiler efficiency, $\eta = 70\%$). [4 Marks]

$$\text{boiler efficiency, } \eta = \frac{\text{Power output of the boiler}}{\text{Energy input to the boiler}}$$

(c) Calculate the air flow rate to the boiler. (Assume 30% excess air is supplied to ensure the complete combustion of wood fuel). [4 Marks]

(d) What is the flue gas flow rate (kg/s) of the boiler? Consider that the flue gasses are leaving the boiler at 170°C temperature. [4 Marks]

(e) Calculate the flue gas heat loss in MW. The ambient temperature is 25°C and specific heating capacity of the flue gas is 1.3 kJ/kg. K (5 Marks)

Hint: *energy carried by a flow stream = (mass flow rate X specific heat capacity X temperature difference)*

Question Three

A farming community in a certain country has decided to convert their diesel engine-based electricity generation system to a wood-fired system. Since the same diesel engine is to be used, wood fuel has to be transformed into an acceptable form of energy for the engine. Therefore, the process of gasification is introduced for the fuel conversion process. The sketch below illustrates the overall process of the proposed bioenergy conversion system to generate electricity. Moist wood entering the system is first subjected to a drying process to reduce the moisture content. Thereafter, the dried wood is fed into the gasifier. In the gasifier, the solid wood is converted into the gaseous fuel and fed to the diesel engine.

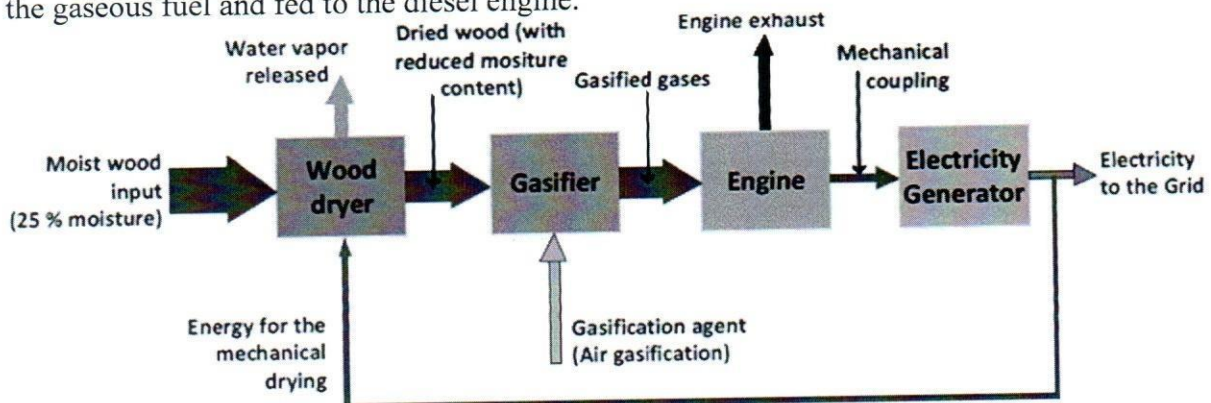

The following information are available regarding the fuel as well as the equipment used in the system.

Fuel: Biomass (wood fuel) Physical properties
 Moisture Content before dryer = 25%

process (kWh/year)

- (h) What is the percentage of electricity consumed for drying process? (%) [2 Marks]
- (i) What alternative is available to consider for reducing the internal energy consumption of drying process (considering that the electrically driven mechanical drying is currently employed)? [2 Marks]

Question Four

The enthusiasm for biomass is based on *five key advantages* that it offers compared to fossil fuels and/or other renewable energy sources:

- (a) Bioenergy is a widely available resource. Explain [4 Marks]
- (b) Unlike other renewable sources, bioenergy is largely available on demand. Explain this fact, and say why it is important [4 Marks]
- (c) Bioenergy is convertible to other convenient energy forms. Explain with example [4 Marks]
- (d) Explain how bioenergy has potential to contribute to greenhouse gas reductions and other environmental objectives [4 Marks]
- (e) Using local examples how bioenergy projects can be a source of income in rural areas [4 Marks]

Question Five

At a sewage treatment works (STW) the biogas produced as an end of anaerobic digestion can fulfil the energy requirements of the STW.

- (a) Explain why 4 different groups of microorganisms are required to produce biogas in a sewage sludge anaerobic digester [8 marks]
- (b) What factors could affect the performance of an AD and what parameters could you control to ensure maximum conversion of organic material in the sewage sludge to biogas? [8 marks]
- (c) Outline the main components of a scheme for utilization of [4 marks]

biogas at a sewage treatment works.